

LEVEL CONTROL

Bleeding and venting valve EB 3.52

Start-up bleeding valve for small to medium flow rates

MANKENBERG

Technical data

Connection DN	25 - 100
Nominal pressure PN	16
Operating pressure	0.3 - 12 bar (DN 25 - 50) 0.3 - 13 bar (DN 65 - 100)
Flow rate	1935 Nm ³ /h
Temperature	130 °C
Medium	liquids

Description

Start-up bleed valves remove air or gases from systems or pipelines during the filling process without requiring an external energy input. When a system is drained they act as venting valves; venting may be prevented by fitting a commercial check valve to the outlet.

Thanks to the large cross-sectional area of the seat these valves are capable of handling large air volumes at low pressures. They close as soon as the system is filled with fluid. When the liquid level drops these valves will only open if the system is depressurised; they will not open under working pressure.

EB 3.52 is a float-controlled start-up bleed valve manufactured completely from deep-drawn stainless steel components featuring excellent corrosion resistance. The float is precisely guided in the outlet spigot. The valve cone is fitted with a soft seal. The minimum pressure required for valve sealing is 0.3 bar.

Top and bottom sections of the valve body are connected by a clamp ring and two bolts. Servicing/maintenance is easy and does not call for special tooling.

Standard

- » All stainless steel construction
- » Quick-release body clamp ring

Options

- » Working pressure up to 16 bar
- » Various seal materials suitable for your medium
- » Plastic coating for corrosive fluids
- » Non-return valve to prevent venting
- » Special connections: Aseptic, ANSI or JIS flanges, welding spigots; other connections on request
- » Special versions on request

Product



Picture similar

Technical specification

Start-up bleeding air flow rate [Nm³/h] at 0 °C, 1013 mbar

Δp bar	nominal diameter						
	DN 25	DN 32	DN 40	DN 50	DN 65	DN 80	DN 100
0.05	52	90	125	217	378	543	790
0.1	73	126	177	307	534	767	1117
0.2	104	178	250	435	755	1085	1580
0.3	127	219	306	532	925	1330	1935

Venting air flow rate [Nm³/h] at 0 °C, 1013 mbar

Δp bar	nominal diameter						
	DN 25	DN 32	DN 40	DN 50	DN 65	DN 80	DN 100
0.1	69	120	167	291	507	728	1060
0.2	93	160	223	390	675	970	1410
0.3	106	183	255	445	775	1110	1620
0.4	114	195	275	475	825	1185	1730

Bleeding and venting valve EB 3.52

Start-up bleeding valve for small to medium flow rates

Materials

Materials*	
Body	Stainless steel
Body seal	EPDM
Internals	Stainless steel
Float	Stainless steel
Valve seal	EPDM
Profile clamp	Stainless steel

*All materials equal or of higher quality

Dimensions and weights

Dimensions [mm]							
size	nominal diameter DN						
	25	32	40	50	65	80	100
A*	247	255	257	261	430	440	440
D	200	200	200	200	265	265	265
E _{max.}	22	16	16	11	-	-	-

*overall length tolerances in acc. with DIN EN 558

Weight [kg]							
nominal diameter DN							
25	32	40	50	65	80	100	
4.5	6	6.5	8.5	15	16	18	

Customs tariff number	
84818059	

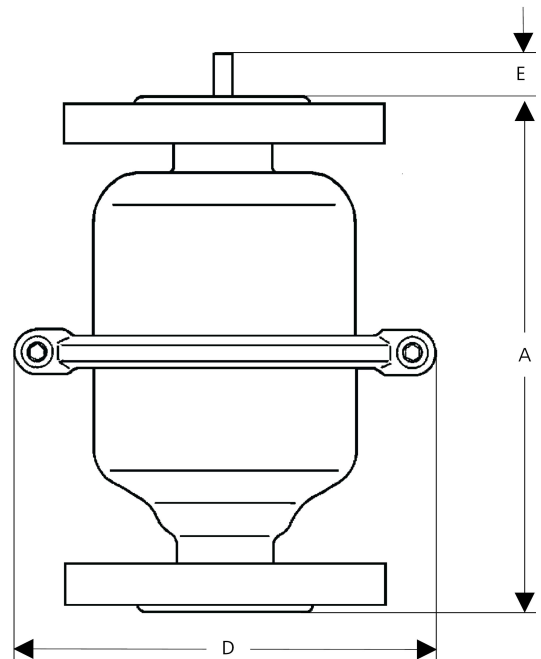

Please send us your enquiry and allow us to advise you. Special designs on request.
The pressure has always been indicated as overpressure. Mankenberg reserves the right to alter technical specifications without notice.