



LRS 1-50

Directives and standards

EC Pressure Equipment Directive 97/23/EC

The conductivity control & monitoring equipment LRG 1-..., LRS 1-5..., LRR 1-5... meets the safety requirements of the Pressure Equipment Directive (PED). The conductivity control & monitoring equipment is EC type approved according to EN 12952/EN 12953. These Directives state, among other things, the requirements made on limiting systems and equipment for steam boiler plants and (pressurized) hotwater installations.

VdTÜV Bulletin "Water Monitoring 100"

The conductivity switch LRS 1-50 in conjunction with the conductivity electrode LRG 1-... is type approved according to VdTÜV Bulletin "Water Monitoring 100". Type approval no. TÜV · WÜL · 12-018 (see name plate). The VdTÜV Bulletin "Water Monitoring 100" states the requirements made on water monitoring equipment.

LV (Low Voltage) Directive and EMC (Electromagnetic Compatibility)

The equipment meets the requirements of the Low Voltage Directive 2006/95/EC and the EMC Directive 2004/108/EC.

ATEX (Atmosphère Explosible)

According to the European Directive 94/9/EC the equipment must not be used in potentially explosive areas.

Note:

The conductivity electrodes LRG 12-1, LRG 16-4, LRG 16-9, LRG 17-1 and LRG 19-1 are simple items of electrical equipment as specified in EN 60079-11 section 5.7. According to the European Directive 94/9/EC the equipment must be equipped with approved Zener barriers if used in potentially explosive areas. Applicable in Ex zones 1, 2 (1999/92/EC). The equipment does not bear an Ex marking. The suitability of the Zener barriers is certified in a separate wiring diagram provided by the manufacturer.

UL/cUL (CSA) Approval

The equipment meets the requirements of: UL 508 and CSA C22.2 No. 14-13, Standards for Industrial Control Equipment. File E243189.

Conductivity Switch

LRS 1-50

Description

The conductivity switch LRS 1-50 in conjunction with conductivity electrodes LRG 1-... is used as limit switch, for instance in steam boilers, (pressurized) hot-water installations and condensate and feedwater tanks. The conductivity switch detects and indicates a MIN and a MAX conductivity limit.

The conductivity switch LRS 1-50 can be used in combination with the following conductivity electrodes: LRG 12-1, LRG 16-4, LRG 16-9, LRG 17-1 and LRG 19-1.

Function

The conductivity controller LRS 1-50 in conjunction with the conductivity electrode LRG 16-... measures the electrical conductivity in conductive liquids. The conductivity electrodes LRG 12-1, LRG 16-4, LRG 17-1, or the LRG 16-9 with integrated resistance thermometer for detecting the fluid temperature can be used with the conductivity switch.

When connecting the conductivity electrode LRG 16-4 a reference measurement is taken and by setting the correction factor CF accordingly the conductivity readings are adapted to the specific conditions of the installation.

If the conductivity electrode LRG 16-9 is used, not only the electrical conductivity but also the water temperature will be measured. The conductivity readings can then be referenced to the standard reference temperature of 25 °C and the conductivity value will be automatically compensated for temperature.

For this purpose the water temperature is constantly measured by the conductivity switch and the conductivity reading is automatically compensated as a function of the adjusted temperature coefficient Tk (%/°C). Even if the temperature changes, thanks to the adjusted linear temperature compensation, the measured value is referenced to 25 °C over the whole measuring range and indicated on the 7-segment LED display.

The MAX /MIN limits can be variably adjusted within the measuring range.

When the MIN or MAX limit is reached, the MIN or MAX output contact is switched over and MIN or MAX LED is illuminated. The equipment will be reset once the value passes outside the preset hysteresis.

Any faults or malfunctions in the conductivity electrode, the electrical connection or the settings will be indicated by the 7-segment LED display. In the event of a malfunction a MIN and MAX alarm will be triggered.

If an error occurs in the conductivity switch LRS 1-50, MIN and MAX alarms are raised and the system is restarted.

Parameter settings can be changed or a MIN/MAX alarm be simulated by operating the rotary button.

The electrical conductivity is measured in µS/cm. In some countries ppm (parts per million) is used instead. Conversion: 1µS/cm = 0.5 ppm. The conductivity switch can be adjusted accordingly.

Technical data

Supply voltage

24 VDC, + / -20 %

Fuse

external 0.5 A (semi-delay)

Power consumption

4 VA

Connection of conductivity electrode

1 input for conductivity electrode LRG 12-1, LRG 16-4, LRG 17-1 and LRG 19-1 (cell constant 1 cm-1), 3 poles with screen,

1 input for conductivity electrode LRG 16-9 (cell constant 0.5 cm-1), with integrated resistance thermometer Pt 100, 5 poles with screen

Measuring voltage

0.8 Vss, pulse duty factor tv = 0.5, frequency 20-10000 Hz.

Measuring range

1 to 10,000 µS/cm at 25 °C or 1 to 5,000 ppm at 25 °C.

Correction factor CF

adjustable between 0.05 and 5,000, adjustable in increments of 0.001

Temperature coefficient Tk

0.0 – 3.0 % per °C, adjustable in increments of 0.1

Reset hysteresis

MIN limit: + 3 % of the adjusted MIN limit, MAX limit: - 3 % of the adjusted MAX limit

Outputs

2 volt-free change-over contacts, 8 A 250 V AC / 30 V DC cos φ = 1. Provide inductive loads with RC combinations according to manufacturer's specification to ensure interference suppression.

Indicators and adjusters

1 rotary button with integrated pushbutton for parameter setting and testing MIN / MAX alarm
1 seven-segment LED display, four digits
2 red LEDs for MIN / MAX alarm,
1 four-pole code switch for configuration settings

Housing

Housing material: base: polycarbonate, black
Front: polycarbonate, grey.
Terminal strips separately detachable.
Fixing of housing: Mounting clip on supporting rail TH 35, EN 60715

Electrical safety

Pollution degree 2.

Protection

Housing: IP 40 to EN 60529
Terminal strip: IP 20 to EN 60529

Weight

approx. 0.2 kg

Ambient temperature

when system is switched on: 0 ... 55 °C,
during operation: -10 ... 55 °C

Transport temperature

-20 ... +80 °C (< 100 hours), defrosting time of the de-energized equipment before it can be put into operation: 24 hours.

Storage temperature

-20 ... +70 °C, defrosting time of the de-energized equipment before it can be put into operation: 24 hours.

Relative humidity

max. 95%, no moisture condensation

Conductivity Switch

LRS 1-50

Important Notes

The conductivity switch LRS 1-50 is clipped onto the support rail in the control cabinet.

The equipment is supplied with 24 V DC and fused with an external semi-delay fuse 0.5 A.

The power supply unit must be electrically isolated from dangerous contact voltages and must meet at least the requirements on double or reinforced isolation according to one of the following standards: DIN EN 50178, DIN EN 61010-1, DIN EN 60730-1 or DIN EN 60950.

To prevent the welding together of contacts provide an external slow-blow fuse T 2.5 A or 1.0 A (TRD 604, 72 hrs. operation) for the output contacts.

When switching off inductive loads, voltage spikes are produced that may impair the operation of control systems. Connected inductive loads must be provided with suppressors such as RC combinations as specified by the manufacturer.

To connect the conductivity electrode LRG 12-1, LRG 16-4, LRG 17-1 and LRG 19-1 use screened multi-core control cable with a min. conductor size of 0.5 mm², e. g. LiYCY 3 x 0.5 mm².

For connecting the conductivity electrode LRG 16-9 control cable assemblies of various lengths are available as optional extra.

Note that the recommended control cable is not UV-resistant and, if installed outdoors, must be protected by a UV-resistant plastic tube or cable duct.

If you do not use the above-mentioned control cable assembly, use screened five-core control cable, e. g. LiYCY 5 x 0.5 mm², for connecting the equipment. In addition, connect at the electrode end a screened jack to the control cable.

Max. cable length between conductivity electrode and switch: 30 m, with conductivities from 1 to 10 µS/cm: max. 10 m.

Make sure that connecting cables between the equipment are segregated and run separately from power cables.

When used as conductivity limiter, the conductivity switch LRS 1-50 does not interlock automatically when readings fall below the MAX limit.

If an interlock function is required for the installation it must be provided in the follow-up circuitry (safety circuit). The circuitry must meet the requirements of the EN 50156.

Order & Enquiry Specification

Conductivity switch type LRS 1-50

GESTRA SPECTOR *module*

Conductivity switch with MIN / MAX alarm

Input: 1 input for conductivity electrode

1 input for PT 100 sensor

Output: 2 volt-free change-over contacts for MIN/MAX alarm

1 seven-segment display

Measuring range can be switch-selected between

0.5 – 10,000 µS/cm

Supply voltage: 24 V DC, 4 VA

Supply in accordance with our general terms of business.

GESTRA AG

P. O. Box 10 54 60, D-28054 Bremen, Germany

Münchener Str. 77, D-28215 Bremen, Germany

Tel. 0049 (0) 421 / 35 03-0, Fax 0049 (0) 421 / 35 03-393

E-mail gestra.ag@flowserve.com, Web www.gestra.de

Dimensions

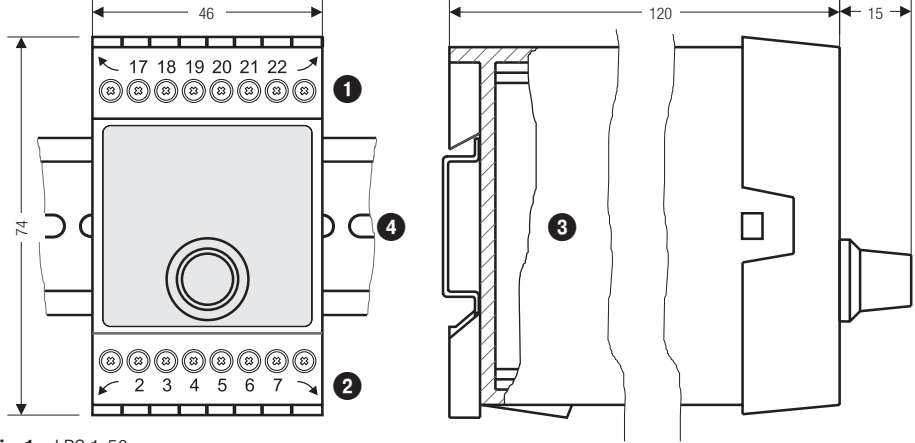

Fig. 1 LRS 1-50

Electrical connection LRS 1-50

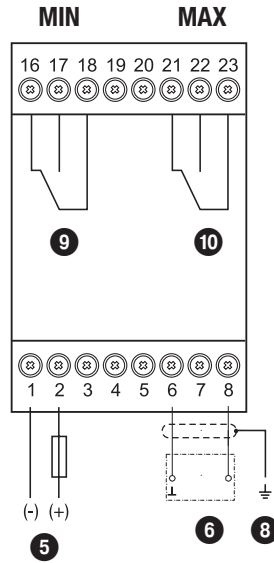

Fig. 2

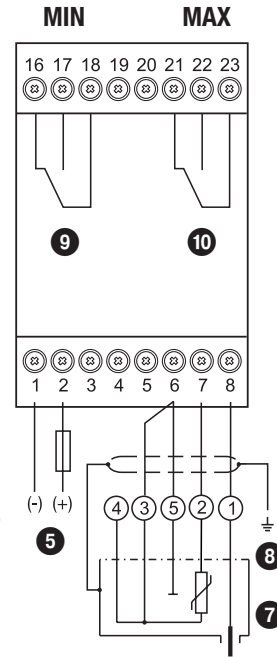

Fig. 3

Key

- 1 Upper terminal strip
- 2 Lower terminal strip
- 3 Housing
- 4 Supporting rail type TH 35, EN 60715
- 5 Connection of supply voltage **24 V DC** with fuse 0.5 A (semi-delay), provided on site
- 6 Conductivity electrode LRG 1-..
- 7 Conductivity electrode LRG 16-9 with integrated resistance thermometer
- 8 Central earthing point (CEP) in control cabinet
- 9 MIN output contact
- 10 MAX output contact



GESTRA