



FLOWSERVE

GESTRA

GESTRA Steam Systems

TRG 5-6..

EN

English

Installation & Operating Instructions 818597-03

Temperature Sensor TRG 5-63, TRG 5-64

Temperature Sensor TRG 5-65, TRG 5-66

Temperature Sensor TRG 5-67, TRG 5-68

Contents

Page

Important notes

Usage for the intended purpose.....	4
Function.....	4
Safety note.....	4

Directives and standards

EC Pressure Equipment Directive 97/23/EC	5
Functional Safety acc. to IEC 61508	5
DIN EN 14597	5
Approvals for Marine Applications	5
ATEX (Atmosphère Explosible)	5
Note on the Declaration of Conformity / Declaration by the Manufacturer CE	5

Technical data

TRG 5-63, TRG 5-64, TRG 5-65, TRG 5-66, TRG 5-67 and TRG 5-68	6
TRG 5-63, TRG 5-64, TRG 5-65, TRG 5-66, TRG 5-67 and TRG 5-68	7
Scope of supply	7
Tolerances of the precision resistor according to EN 60751	8
Name plate / marking	8

Installation

Dimensions TRG 5-63 and TRG 5-64	9
Key	9
Dimensions TRG 5-65, TRG 5-66, TRG 5-67 and TRG 5-68	10
Key	10
TRG 5-63 and TRG 5-64	11
TRG 5-65, TRG 5-66, TRG 5-67 and TRG 5-68	11
Tools	11
Examples of installation	12

Electrical connection

TRG 5-63, TRG 5-64, TRG 5-65, TRG 5-66, TRG 5-67 and TRG 5-68, terminal box	13
Key	13

Electrical connection

Connecting the temperature sensor 14
Connecting the measuring element 14
Wiring diagram for temperature sensor 15
Tools 15
Key 15

Troubleshooting

Indication, diagnosis and remedy 16
Measure the fluid temperature 16
Safety note 17
Replacing the temperature measuring element 17
Spare Parts 17

Removing and disposing of the temperature sensor

Removing and disposing of temperature sensor TRG 5-63 or TRG 5-64 18

Important notes

Usage for the intended purpose

The temperature sensor TRG 5-6.. in conjunction with temperature switches TRS 5-50, TRS 5-52 or with temperature transmitter TRV 5-40 are designed for measuring temperatures in steam or hot water.

Function

The temperature sensors TRG 5-63, TRG 5-65, TRG 5-66 and TRG 5-67 feature one integrated platinum resistance thermometer Pt 100 to EN 60751 each.

The temperature sensors TRG 5-64 and TRG 5-68 are equipped with two platinum resistance thermometers Pt 100 for the connection of additional indicating equipment.

The ohmic resistance of the resistance thermometer changes as a function of temperature. If a constant current is applied, the voltage produced by the change of resistance is measured and further processed in the temperature switch or temperature transmitter.

The temperature sensor can be used as measuring transducer for

- a safety temperature monitor/limiter in conjunction with temperature transmitter TRV 5-40 and control unit NRS 1-40.1
- a temperature monitor/controller in conjunction with temperature transmitter TRV 5-40 and switching controller TRS 5-40
- a safety temperature monitor/limiter in conjunction with temperature switch TRS 5-50
- a temperature monitor in conjunction with temperature switch TRS 5-52

Safety note

Safety temperature limiters/monitors are items of equipment with safety function (PED) and must only be installed, wired and commissioned by qualified and competent staff.

Retrofitting and maintenance work must only be performed by qualified staff who - through adequate training - have achieved a recognised level of competence.



Danger

The temperature sensors TRG 5-63 or TRG 5-64 are screwed into vessels or pipes. When loosening the temperature sensor steam or hot water might escape! This presents the risk of severe scalding all over the body!

It is therefore essential not to dismantle the temperature sensor unless the boiler pressure is verified to be 0 bar.

The temperature sensor becomes hot during operation.

Risk of severe burns to hands and arms.

Before carrying out installation and maintenance work make sure that the equipment is cold.



Attention

The name plate specifies the technical features of the equipment. Note that any piece of equipment without its specific name plate must neither be commissioned nor operated.

Directives and standards

EC Pressure Equipment Directive 97/23/EC

Safety temperature limiters/monitors are safety accessories as defined in the Pressure Equipment Directive (PED). The temperature switch TRS 5-50 and the temperature transmitter TRV 5-40 (together with control unit NRS 1-40.1) in conjunction with temperature sensors TRG 5-6.. are EC type approved according to EN 12952/EN 12953. These Directives state, among other things, the requirements made on limiting systems and equipment for steam boiler plants and (pressurised) hot-water installations.

Functional Safety acc. to IEC 61508

The temperature switch TRS 5-50 and the temperature transmitter TRV 5-40 (together with control unit NRS 1-40.1) in conjunction with temperature sensors TRG 5-6.. are certified to IEC 61508. This standard describes the functional safety of safety-related electrical/electronic/programmable electronic systems.

The equipment combination TRG 5-6.. + TRS 5-50 corresponds to a type B subsystem with Safety Integrity Level (SIL) 3.

The combination TRG 5-6.. + TRV 5-40 (with NRS 1-40.1) corresponds to a type B subsystem with Safety Integrity Level (SIL) 2.

DIN EN 14597

The temperature sensor TRG 5-6.. in conjunction with temperature switches TRS 5-50 and TRS 5-52 or in conjunction with temperature transmitter TRV 5-40 (together with control unit NRS 1-40.1) is type approved to DIN EN 14597.

DIN EN 14597 describes and specifies the requirements made on (safety) temperature limiters/monitors.

Approvals for Marine Applications

The temperature sensor TRG 5-6.. in conjunction with temperature switch TRS 5-50 is approved for marine applications.

ATEX (Atmosphère Explosible)

According to the European Directive 94/9/EC the equipment must **not** be used in explosion-risk areas.

Note on the Declaration of Conformity / Declaration by the Manufacturer CE

For details on the conformity of our equipment according to the European Directives see our Declaration of Conformity or our Declaration of Manufacturer.

The current Declaration of Conformity / Declaration of Manufacturer are available in the Internet under www.gestra.com/documents or can be requested from us.

Technical data

TRG 5-63, TRG 5-64, TRG 5-65, TRG 5-66, TRG 5-67 and TRG 5-68

Measuring element (3-wire connection)

TRG 5-63

1 x Pt 100 to EN 60751, class A*)

TRG 5-64

2 x Pt 100 to EN 60751, class A*)

TRG 5-65, TRG 5-66

1 x Pt 100 to EN 60751, up to 300°C class A*), > 300°C class B*)

TRG 5-67

1 x Pt 100 to EN 60751, class B*)

TRG 5-68

2 x Pt 100 to EN 60751, class B*)

Service pressure, service temperature

TRG 5-63, TRG 5-64

Nominal length 100, 160, 250 mm

36 bar at 251°C

Nominal length 400 mm

18 bar at 400°C

TRG 5-65, TRG 5-66

160 bar at 345°C

120 bar at 540°C

TRG 5-67, TRG 5-68

150 bar at 600°C

Admissible flow velocity

TRG 5-63, TRG 5-64

Air 25 m/s

Superheated steam 25 m/s

Water 3 m/s

Nominal length 400 mm

Water 2.4 m/s

TRG 5-65, TRG 5-66, TRG 5-67, TRG 5-68

Air 60 m/s

Superheated steam 60 m/s

Water 5 m/s

Mechanical connection

TRG 5-63, TRG 5-64

Thread G ½ A, ISO 228

TRG 5-65, TRG 5-66, TRG 5-67, TRG 5-68

Welding sleeve

Protection tube, welding sleeve

Dimensions see pages 9, 10

Technical data - continued -

TRG 5-63, TRG 5-64, TRG 5-65, TRG 5-66, TRG 5-67 and TRG 5-68 - continued -

Materials

TRG 5-63, TRG 5-64

Protection tube 1.4571, X6CrNiMoTi17122

TRG 5-65, TRG 5-66

Welding sleeve 1.7335

TRG 5-67, TRG 5-68

Welding sleeve 1.4961

Ambient temperature at terminal box

Max. 70°C

Protection

IP 66 to DIN EN 60529

Cable entry / Electrical connection

EMC cable gland with integral cable clamp M 20x1.5

Weight

TRG 5-63, TRG 5-64

approx. 0.5 kg

TRG 5-65, TRG 5-66

approx. 0.6 kg

TRG 5-67, TRG 5-68

approx. 1 kg

Approvals:

EC Type approval

PED Pressure Equipment Directive 97/23/EC,
EN 12952-11, EN 12953-09: Requirements made on limiting equipment
for boilers.

Functional Safety acc. to
SIL 3

EN 61508: Functional safety of safety-related electrical/electronic/
programmable/electronic systems

Type approval

DIN EN 14597:

Requirements made on safety temperature limiters/monitors

DIN Registration number (see name plate)

TRG 5-6../TRV 5-40, NRS 1-40.1 DIN safety temp. monitor (/limiter)
STW(STB) 117908

TRG 5-6../TRV 5-40, NRS 5-40 DIN temp. controller/monitor (TR/TW) 1182

TRG 5-6../TRS 5-50 DIN safety temp. monitor (/limiter) STW(STB) 1230

TRG 5-6../TRS 5-52 DIN temp. monitor (TW) 1232

Marine applications

In accordance with classification society, GL 47399-12 HH

Scope of supply

TRG 5-63, TRG 5-64, TRG 5-65, TRG 5-66, TRG 5-67 and TRG 5-68

1 Temperature sensor

1 Installation manual

Tolerances of the precision resistor according to EN 60751

*) Class A and B, admissible tolerances of the precision resistor

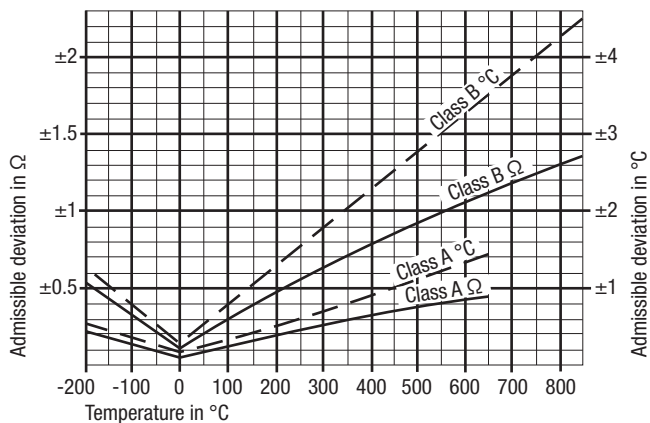

Name plate / marking

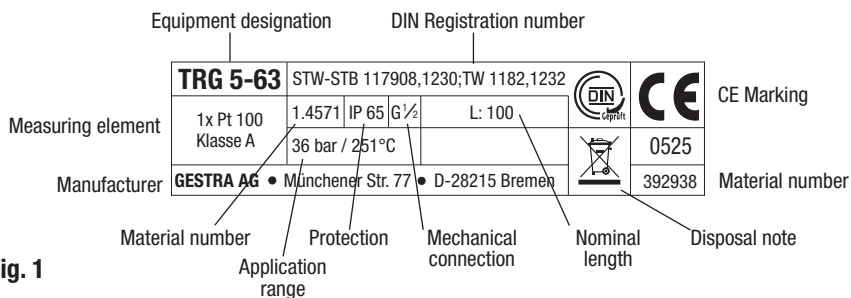

Fig. 1

Installation

Dimensions TRG 5-63 and TRG 5-64

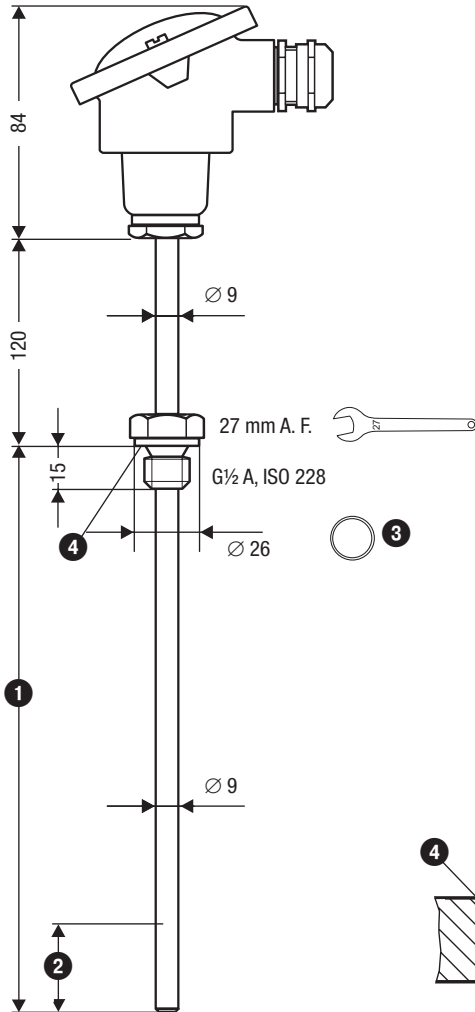

Fig. 2

1 [mm]	2 [mm]
100	30
160	30
250	30
400	30

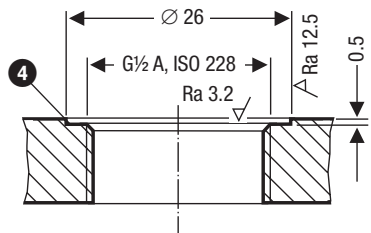
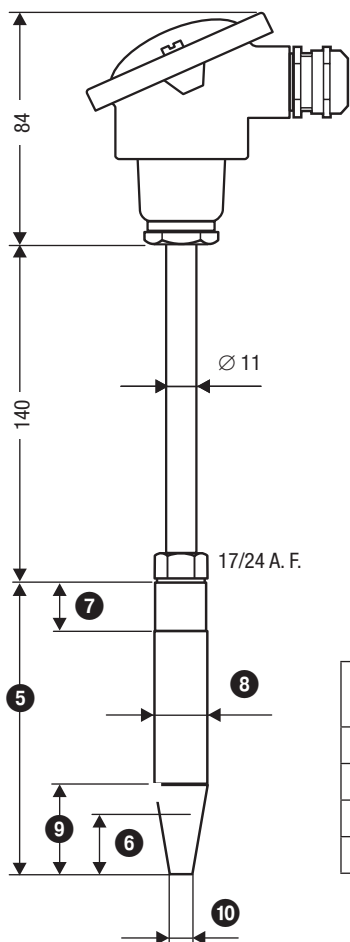

Fig. 3

Key

- 1 Length of protection tube
- 2 Temperature-sensitive length
- 3 Joint ring $\varnothing 13 \times 26$
- 4 Sealing surface

Dimensions TRG 5-65, TRG 5-66, TRG 5-67 and TRG 5-68



	5	6	7	8	9	10
	[mm]	[mm]	[mm]	[mm]	[mm]	[mm]
TRG 5-65	115	30	25	18	40	9
TRG 5-66	140	30	25	18	65	9
TRG 5-67	200	30	25	24	65	12.5
TRG 5-68	200	30	25	24	65	12.5

Fig. 4

Key

- 5 Length of welding sleeve
- 6 Temperature-sensitive length
- 7 Threaded part
- 8 Diameter of welding sleeve
- 9 Cone-shaped part
- 10 Tip of cone-shaped part

Installation - continued -



Note

- To install the temperature sensor in a pipe, weld the elbow (13) onto it. This ensures that the temperature sensitive part (2), (6) of the temperature sensor is immersed in the fluid against the flow direction **Fig. 7 and Fig. 8**
- Install the temperature sensor such that the temperature-sensitive part (2), (6) is permanently immersed in the fluid. **Fig. 2 and Fig. 4**



Attention

- The seating surfaces of the threaded standpipe or the flange provided on the vessel must be accurately machined, see **Fig. 3**.
- Do not completely insulate the temperature sensor. See examples of installation in vessel **Fig. 5 and Fig. 6**
- Only qualified welders certified according to EN 287-1 may weld welding sleeves into lines or vessels.

TRG 5-63 and TRG 5-64

1. Check seating surfaces. **Fig. 3**
2. Put joint ring (3) onto the sealing surface of the threaded standpipe or flange provided on the vessel (select joint ring material according to the range of application). **Fig. 3**
3. Screw in the temperature sensor and fasten it with an open-end spanner 27 mm A. F. The torque required **when cold is 150 Nm**.

TRG 5-65, TRG 5-66, TRG 5-67 and TRG 5-68

1. Provide a penetration for the socket-weld end on site.
2. Unscrew the upper part of the temperature sensor from the welding sleeve (5).
3. Weld the welding sleeve (5) in place. Arc-weld the equipment in place, applying welding process 111 and 141 in accordance with ISO 4063.
4. Put copper ring onto welding sleeve (5) and screw the upper part of the temperature sensor into the welding sleeve (5). Fasten the upper part of the temperature sensor when cold with an open-end spanner (17 or 24 mm A. F.).

Tools

- Open-end spanner 17 mm A. F.
- Open-end spanner 24 mm A. F.
- Open-end spanner 27 mm A. F.

Examples of installation

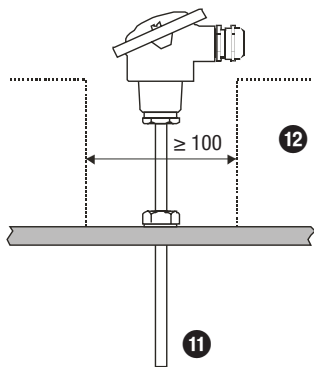

Fig. 5

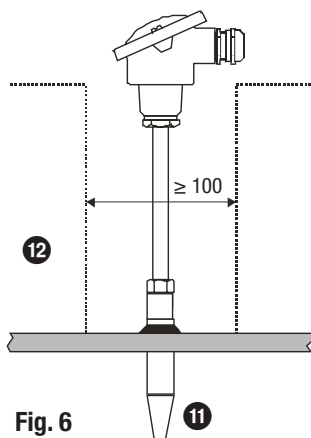

Fig. 6

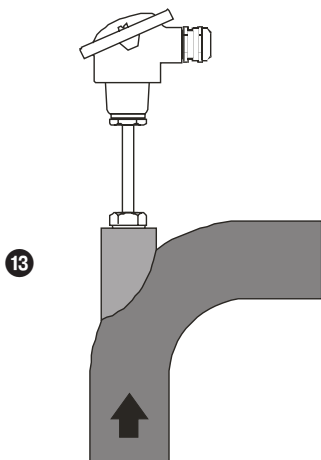

Fig. 7

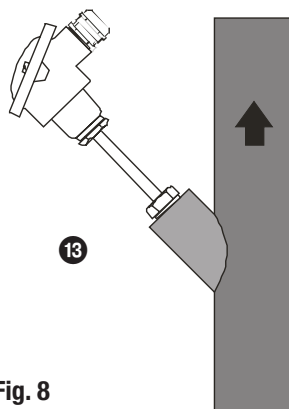

Fig. 8

Electrical connection

TRG 5-63, TRG 5-64, TRG 5-65, TRG 5-66, TRG 5-67 and TRG 5-68, terminal box

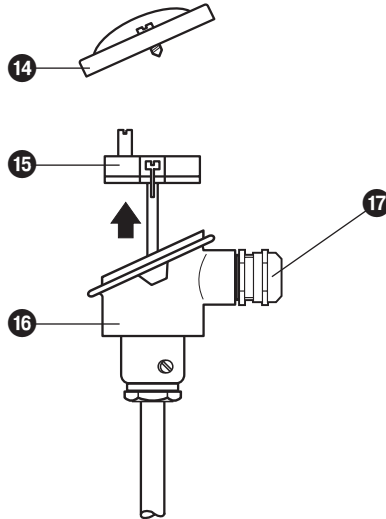

Fig. 9

Key

- 11 Protection tube / welding sleeve
- 12 Thermal insulation
- 13 Elbow
- 14 Top of terminal box
- 15 Measuring insert
- 16 Terminal box
- 17 EMC cable gland M 20 x 1.5

Electrical connection

Connecting the temperature sensor

To connect the temperature sensor please use:

- To connect the **temperature transmitter TRV 5-40**: screened four-core cable, e. g. Ölflex 110 CH, manufactured by Lapp, 4 x 0.5 mm². Max. length 25 m.
- To connect the **temperature switches TRS 5-50 and TRS 5-52**: Multi-core screened control cable, min. conductor size 0.5 mm², e. g. LiYCY 3 x 0.5 mm², max. length 100 m.

Note that **only** the cable gland of the temperature sensor provides the screen.

Connecting the measuring element

1. Take cover **14** off the terminal box **16**.
2. Unscrew dome nut **18** of cable gland **17** and take out the lamellar insert **20**. **Fig. 9 and 10**
3. Cut off outer cable sheath **23** and expose braided screen **21** over a length of approx. 10 - 15 mm.
4. Push dome nut **18** and lamellar insert **20** with sealing ring **19** onto the cable **23**.
5. Bend braided screen **21** outwards at a right angle (90°).
6. Fold braided screen **21** towards outer sheath, i. e. by another 180°.
7. Push lamellar insert **20** with sealing ring **19** into gland body **22** and turn it briefly around both sides of the cable axis and snap anti-rotation element into place.
8. Firmly screw on dome nut **18**.
9. Connect the connecting cable in accordance with the wiring diagram to the measuring element **15**.
10. Replace cover **14** and tighten screw securely.

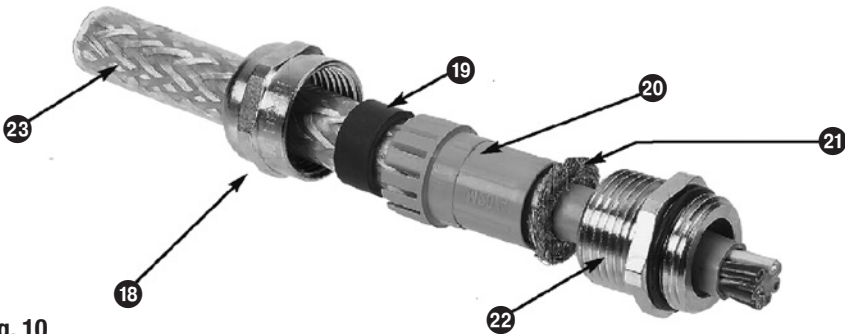

Fig. 10



Attention

- Please observe the installation & operating manuals for the temperature transmitter TRV 5-40 and the temperature switches TRS 5-50 and TRS 5-52.
- Make sure that connecting cables leading to the equipment are segregated and run separately from power cables.

Wiring diagram for temperature sensor

TRG 5-63, TRG 5-65,
TRG 5-66, TRG 5-67

TRG 5-64
TRG 5-68

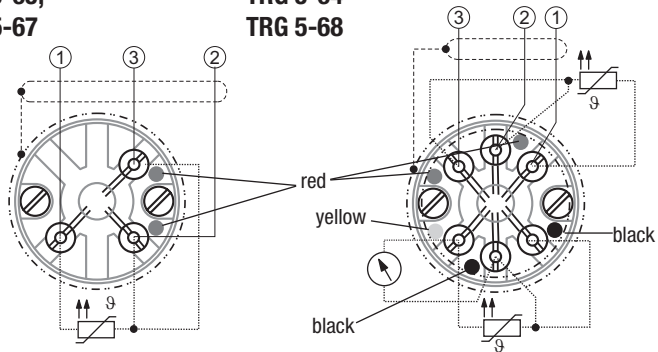

Fig. 11



Note

Additional equipment such as indicating devices can be connected to the terminals marked in yellow and black of the TRG 5-64 and TRG 5-68.

Tools

- Screwdriver, size 2.5, completely insulated according to DIN VDE 0680-1
- Screwdriver, size 8

Key

- 18 Dome nut
- 19 Sealing ring
- 20 Lamellar insert
- 21 Braided screen
- 22 Gland body
- 23 Screened cable

Troubleshooting

Indication, diagnosis and remedy



Attention

Before carrying out the fault diagnosis please check:

Supply voltage:

Is the temperature transmitter or temperature switch supplied with the mains voltage specified on the name plate?

Wiring:

Is the wiring in accordance with the wiring diagram?

Faults indicated by the seven-segment display (TRS 5-52) or the seven-segment display on the right (TRV 5-40, TRS 5-50)		
Error code	Error	Remedy
E.xxx	Temperature sensor defective, temperature reading too low.	Check whether the temperature sensor outputs correct readings (see Fig. 12). If there are any deviations please replace the measuring element with a new one. Check the sensor lines (short circuit, interruption?).
E.xxx	Temperature sensor defective, temperature reading too high.	

Fault code see installation and operating manuals for temperature transmitter TRV 5-40 and for temperature switches TRS 5-50 and TRS 5-52.

Measure the fluid temperature

Use table Fig. 12 to ascertain the current temperature of the fluid via the resistance value of the Pt 100.

1. Take cover 14 off the terminal box .
2. Connect test cable directly to the measuring element 15.
3. Use an ohmmeter for measuring the resistance value.
4. Look up the corresponding resistance value in the table, interpolate if necessary and read off the temperature.
5. After measurement replace cover 14 and fix it securely in place.

°C	0	10	20	30	40	50	60	70	80	90	100	Ω/deg
0	100.00	103.90	107.79	111.67	115.54	119.40	123.24	127.07	130.89	134.70	138.50	0.385
100	138.50	142.28	146.06	149.82	153.57	157.32	161.04	164.76	168.47	172.16	175.84	0.373
200	175.84	179.51	183.17	186.82	190.46	194.08	197.70	201.30	204.88	208.46	212.03	0.361
300	212.03	215.58	219.13	222.66	226.18	229.69	233.19	236.67	240.15	243.61	247.06	0.350
400	247.06	250.50	253.93	257.34	260.75	264.14	267.52	270.89	274.25	277.60	280.93	0.338
500	280.93	284.26	287.57	290.87	294.16	297.43	300.70	303.95	307.20	310.43	313.65	0.327
600	313.65	316.86	320.05	323.24	326.41	329.57	332.72	335.86	338.99	342.10	345.21	0.315
700	345.21	348.30	351.38	354.45	357.51	360.55	363.59	366.61	369.62	372.62	375.61	0.304
800	375.61	378.59	381.55	384.50	387.45	390.38						0.295

Basic values of the precision resistors according to DIN 43760 for Pt 100.

Fig. 12

Safety note

Safety temperature limiters/monitors are items of equipment with safety function (PED) and must only be installed, wired and commissioned by qualified and competent staff.

Retrofitting and maintenance work must only be performed by qualified staff who - through adequate training - have achieved a recognised level of competence.



Attention

- Refer to the installation and operating manuals of the temperature transmitter TRV 5-40 and the temperature switches TRS 5-50 and TRS 5-52 for commissioning, for more information on indicated fault code E.xxx and for further diagnosis and troubleshooting.
- Please replace the measuring element if the temperature measured by the temperature sensor deviates from the plant temperature.
- The measuring element must also be replaced by a new one if a malfunction occurred and the rated service pressure and temperature limits were exceeded.

Replacing the temperature measuring element

The temperature measuring element 15 can be replaced during operation if necessary.

1. Disconnect supply voltage (TRV 5-40, TRS 5-50, TRS 5-52).
2. Take cover 14 off the terminal box .
3. Disconnect the measuring element 15.
4. Slacken fixing screws for measuring element. Pull out measuring element.
5. Insert new measuring element and fasten fixing screws.
6. Re-attach the measuring element 15.
7. Replace cover 14 and tighten screw securely.
8. Apply supply voltage.

Spare Parts

Temperature sensor type	Designation	Item	Stock code #
TRG 5-65: Nominal length 5 = 115 mm, Fig. 4	Measuring element, 1x Pt 100	15	392962
TRG 5-66: Nominal length 5 = 140 mm, Fig. 4	Measuring element, 1x Pt 100	15	392963
TRG 5-67: Nominal length 5 = 200 mm, Fig. 4	Measuring element, 1x Pt 100	15	392946
TRG 5-68: Nominal length 5 = 200 mm, Fig. 4	Measuring element, 2x Pt 100	15	392948

Removing and disposing of the temperature sensor



Danger

The temperature sensors TRG 5-63 or TRG 5-64 are screwed into vessels or pipes. When loosening the temperature sensor steam or hot water might escape! This presents the risk of severe scalding all over the body!

It is therefore essential not to dismantle the temperature sensor unless the boiler pressure is verified to be 0 bar.

The temperature sensor becomes hot during operation.

Risk of severe burns to hands and arms.

Before carrying out installation and maintenance work make sure that the equipment is cold.

Removing and disposing of temperature sensor TRG 5-63 or TRG 5-64

1. Disconnect supply voltage (TRV 5-40, TRS 5-50, TRS 5-52).
2. Take cover ⑭ off the terminal box .
3. Disconnect the measuring element ⑮ and pull line ⑯ out of the cable gland.
4. Before removing the equipment make sure that is is neither hot nor under pressure.

For the disposal of the equipment observe the pertinent legal regulations concerning waste disposal.

If faults occur that are not listed above or cannot be corrected, please contact our service centre or authorized agency in your country.



GESTRA

Agencies all over the world:

www.gestra.com

Belgique

MRC Transmark n.v.

Bredastraat 129/133

B-2060 Antwerpen

Tel. 0032 3 / 2 05 13 20

Fax 0032 3 / 2 32 84 34

E-Mail belgium@mrctransmark.com

Web www.mrctransmark.com

France

MRC Transmark France SAS

23, Boulevard de l'Oise

CS 20515

95031 Cergy Pontoise Cedex

Tel. 00 33 (0)1 30 73 61 00

Fax 00 33 (0)1 30 73 61 01

E mail info-vapeur@mrcglobal.com

Web www.mrcglobal.com

GESTRA AG

P. O Box 10 54 60, D-28054 Bremen

Münchener Str. 77, D-28215 Bremen

Tel. 0049 (0) 421 / 35 03-0

Fax 0049 (0) 421 / 35 03-393

E-mail gestra.ag@flowserve.com

Web www.gestra.com

