



GESTRA Steam Systems

NRS 1-52

EN
English

Installation & Operating Instructions **819176-00**

Level Switch NRS 1-52

Contents

Page

Important notes

Usage for the intended purpose	4
Function	4
Safety note	4

Directives and standards

VdTÜV Bulletin "Wasserstand 100" (= Water Level 100)	5
LV (Low Voltage) Directive and EMC (Electromagnetic Compatibility)	5
ATEX (Atmosphère Explosible)	5
Note on the Declaration of Conformity / Declaration by the Manufacturer CE	5

Technical data

NRS 1-52	6 – 7
Scope of supply	7

In control cabinet: Mounting level switch

Dimensions NRS 1-52	8
Key	8
Installation in control cabinet	8
Name plate / marking	9

In control cabinet: Wiring level switch

Wiring diagram for level switch NRS 1-52	10
Key	10
Connecting supply voltage	11
Connecting MIN/MAX output contact	11
Connecting level electrode	11
Tools	11

In the plant: Wiring level electrode

Connecting several level electrodes	12
Key	12
Connection of level electrode	12

Contents - continued -

Page

Factory settings

Factory setting 13

Commissioning procedure

Changing response sensitivity 14

Checking switchpoints and functions 15 - 16

Operation, alarm and test

Indications and operation 17

Further notes

Protection against high frequency interference 19

Decommissioning / replacing the equipment 19

Disposal 19

Important Notes

Usage for the intended purpose

The level switch NRS 1-52 in conjunction with level electrodes NRG 1-.. and ER 5. is used as limit switch, for instance in steam boilers, (pressurized) hot-water installations as well as condensate and feedwater tanks. The level switch detects and indicates a MIN and a MAX water level.

The level switch NRS 1-52 can be used in combination with the following level electrodes:

Level electrodes				
NRG 10-52, NRG 16-52 Electrode with 4 rods	NRG 16-36 Electrode with 4 rods	NRG 16-4 Electrode with 1 rod	ER 50 Electrode with 4 rods	ER 56 Electrode with 4 rods

Function

The operation of the level switch NRS 1-52 is based on the conductive measuring principle using the electrical conductivity of the water for signalling water level. The level switch is designed for different electrical conductivities and for connecting two level electrodes.

The length of the associated electrode rod determines the MIN and MAX water level switchpoints.

The level switch detects that the MIN or MAX water level is reached when the corresponding electrode rod is exposed or submerged. After the de-energizing delay has elapsed, the MIN or MAX output contact is switched over. At the same time the MIN or MAX LED changes from green to red.

A MIN or MAX alarm can be simulated by pressing the button "Test".

Safety note

The equipment must only be installed, wired and commissioned by qualified and competent staff.

Retrofitting and maintenance work must only be performed by qualified staff who - through adequate training - have achieved a recognised level of competence.



Danger

The terminal strips of the equipment are live during operation.

This presents the danger of electric shock!

Always cut off power supply to the equipment before mounting, removing or connecting the terminal strips!



Attention

The name plate specifies the technical features of the equipment. Note that any piece of equipment without its specific name plate must neither be commissioned nor operated.

Directives and Standards

VdTÜV Bulletin “Wasserstand 100” (= Water Level 100)

The level switch NRS 1-52 in conjunction with level electrodes NRG 10-52, NRG 16-52, NRG 16-36, NRG 16-4 and ER 5.-1 is type approved to VdTÜV Bulletin “Water Level 100”. The VdTÜV Bulletin “Wasserstand (= Water Level) 100” specifies the requirements made on water level control and limiting equipment for boilers.

LV (Low Voltage) Directive and EMC (Electromagnetic Compatibility)

The equipment meets the requirements of the Low Voltage Directive 2006/95/EC and the EMC Directive 2004/108/EC.

ATEX (Atmosphère Explosible)

According to the European Directive 94/9/EC the equipment must **not** be used in explosion risk areas.



Note

The level electrodes NRG 10-52, NRG 16-52, NRG 16-36, NRG 16-4 and ER 5.-1 are simple items of electrical equipment as specified in EN 60079-11 section 5.7.

According to the European Directive 94/9/EC the equipment must be equipped with approved Zener barriers if used in potentially explosive areas.

Applicable in Ex zones 1, 2 (1999/92/EC).

The equipment does not bear an Ex marking. The suitability of the Zener barriers is certified in a separate wiring diagram provided by the manufacturer.

Note on the Declaration of Conformity / Declaration by the Manufacturer CE

For details on the conformity of our equipment according to the European Directives see our Declaration of Conformity or our Declaration of Manufacturer.

The current Declaration of Conformity / Declaration of Manufacturer are available in the Internet under www.gestra.com/documents or can be requested from us.

Technical Data

NRS 1-52

Supply voltage

24 VDC +/- 20 %

Fuse

external 0.5 A (semi-delay)

Power consumption

2 VA

Connection of level electrode

2 inputs for level electrode NRG 10-52, NRG 16-52, NRG 16-36, NRG 16-4 and ER 5.-1,
4 poles with screen

Electrode voltage

5 V_{SS}

Response sensitivity (Electrical conductivity of water at 25 °C)

> 0.5 ... < 1000 µS/cm or > 10 ... < 10 000 µS/cm (switch-selectable)

Outputs

2 volt-free change-over contacts, 8 A 250 V AC / 30 V DC cos φ = 1.

De-energizing delay: 3 sec.

Provide inductive loads with RC combinations according to manufacturer's specification to ensure interference suppression.

Indicators and adjustors

1 pushbutton "Test" for simulating MIN / MAX alarm,

2 red/green LEDs for indicating operating mode and MIN / MAX alarm,

1 green LED indicating "Power ON",

1 code switch with 4 poles for changing the sensitivity

Housing

Housing material: base: polycarbonate, black; front: polycarbonate, grey

Conductor size: 1 x 4.0 mm² solid per wire or

1 x 2.5 mm² per stranded wire with sleeve to DIN 46228 or

2 x 1.4 mm² per stranded wire with sleeve to DIN 46228;

Terminal strips can be detached

Fixing of housing: Mounting clip on supporting rail TH 35, EN 60715

Electrical safety

Pollution degree 2 for installation in control cabinet with protection IP 54, completely insulated

Protection

Housing: IP 40 to EN 60529

Terminal strip: IP 20 to EN 60529

Weight

approx. 0.2 kg

Technical Data - continued -

NRS 1-52 - continued -

Ambient temperature

when system is switched on: 0 ° 55 °C,
during operation: -10 ... 55 °C

Transport temperature

-20 ... +80 °C (< 100 hours), defrosting time of the de-energized equipment before it can be put into operation: 24 hours.

Storage temperature

-20 ... +70 °C, defrosting time of the de-energized equipment before it can be put into operation: 24 hours.

Relative humidity

max. 95 %, no moisture condensation

Approvals:

TÜV certificate VdTÜV Bulletin "Water Lever 100"
 Requirements made on water level limiting & control equipment.
 Type approval no. TÜV . WR/WB . XX-424
 (see name plate)

Scope of supply

NRS 1-52

1 Level switch NRS 1-52
1 Installation manual

In control cabinet: Mounting level switch

Dimensions NRS 1-5..

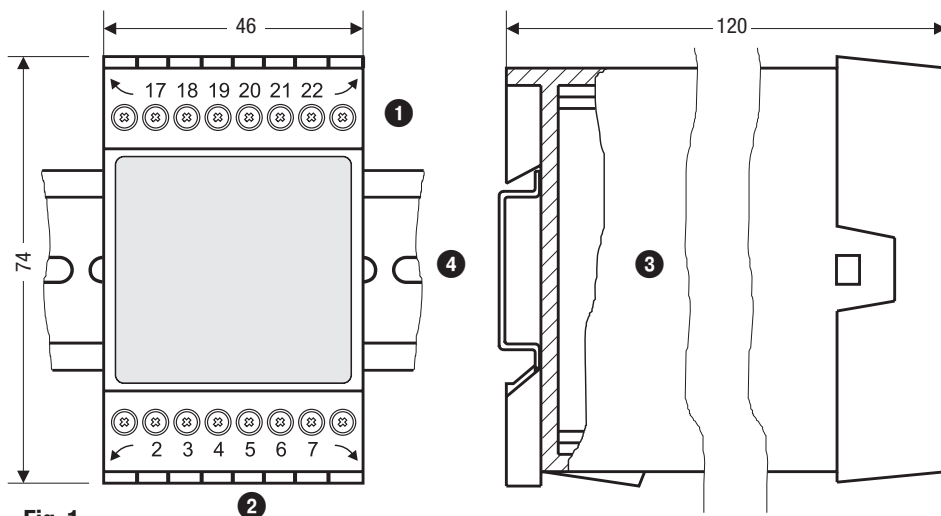

Fig. 1

Key

- | | |
|------------------------|--|
| 1 Upper terminal strip | 3 Housing |
| 2 Lower terminal strip | 4 Supporting rail type TH 35, EN 60715 |

Installation in control cabinet

The level switch NRS 1-52 is clipped onto the support rail 4 type TH 35, EN 60715 in the control cabinet. **Fig. 1**

Name plate / marking

Name plate (on top)

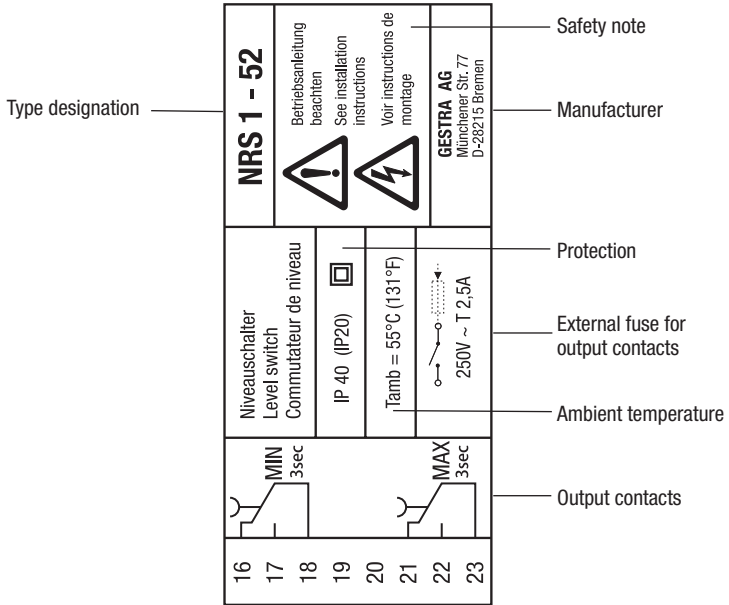

Name plate (at the bottom)

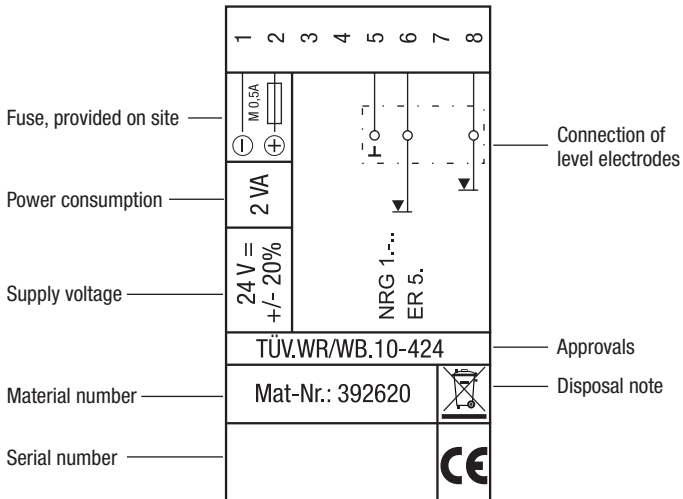

Fig. 2

In control cabinet: Wiring level switch

Wiring diagram for level switch NRS 1-52

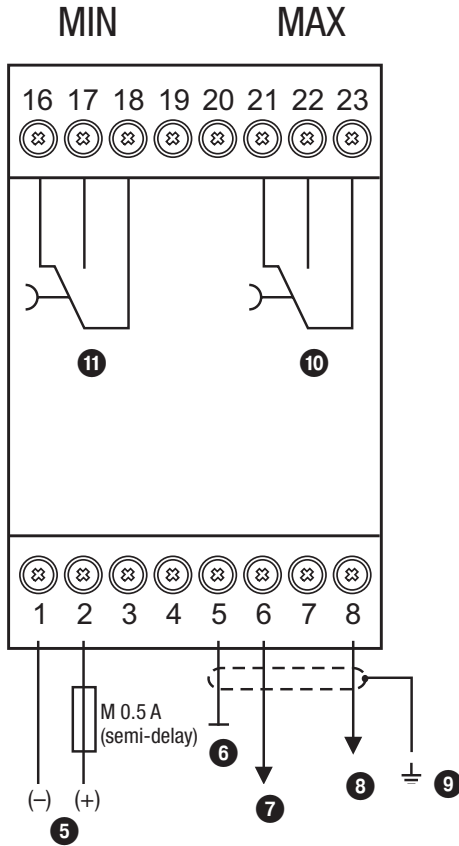

Fig. 3

Key

- 5 Connection of supply voltage **24 V DC** with fuse 0.5 A (semi-delay) provided on site
- 6 Reference electrode or vessel used as functional earth
- 7 MIN electrode rod
- 8 MAX electrode rod
- 9 Central earthing point (CEP) in control cabinet
- 10 MAX output contact
- 11 MIN output contact

In control cabinet: Wiring level switch - continued -

Connecting supply voltage

The equipment is supplied with 24 V DC and fused with an external semi-delay fuse 0.5 A. Please use a power supply unit with safe electrical isolation.

The power supply unit must be electrically isolated from dangerous contact voltages and must meet at least the requirements on double or reinforced isolation according to one of the following standards: DIN EN 50178, DIN EN 61010-1, DIN EN 60730-1 or DIN EN 60950.

Connecting MIN/MAX output contact

Wire the upper terminal strip **1** (terminals 16-18, 21-23) according to the desired switching functions. Provide an external slow-blow fuse 2.5 A for the output contacts.

When switching off inductive loads, voltage spikes are produced that may impair the operation of control and measuring systems. Connected inductive loads must be provided with suppressors such as RC combinations as specified by the manufacturer.

Connecting level electrode

To connect the level electrode(s) use screened multi-core control cable with a min. conductor size 0.5 mm², e. g. LiYCY 3 x 0.5 mm², max. length: 100 m.

Wire terminal strip in accordance with the wiring diagram. **Fig. 3.**

Connect the screen **only once** to the central earthing point (CEP) in the control cabinet.

Make sure that connecting cables leading to the level electrodes are segregated and run separately from power cables.



Attention

- Do not use unused terminals as support point terminals.

Tools

- For all functions: Screwdriver 0.8 x 4.0 or 0.8 x 4.5, completely insulated according to VDE 0680-1.

In the plant: Wiring level electrode

Connecting several level electrodes

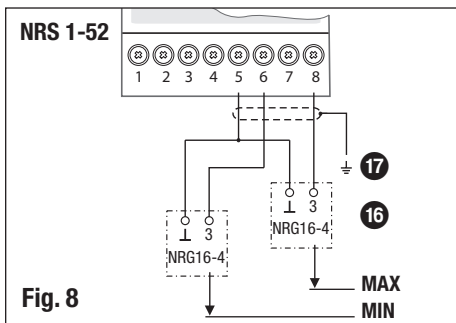
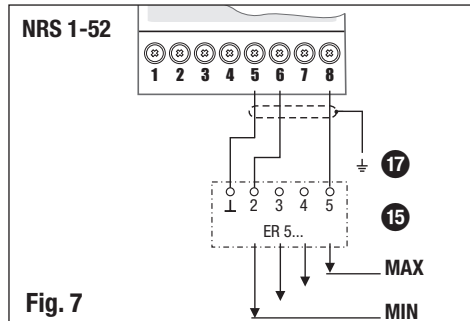
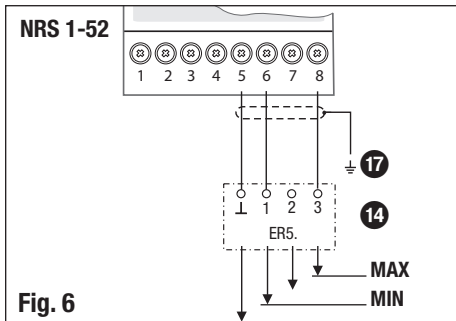
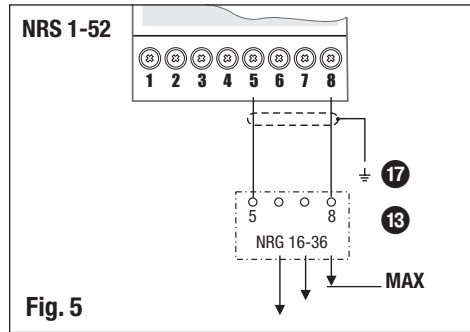
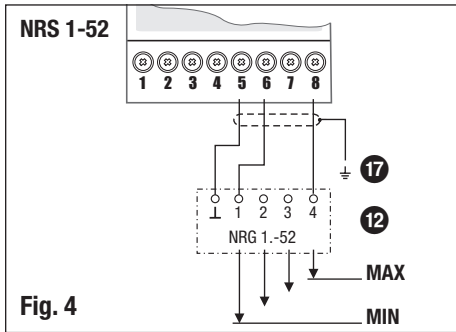

Key

- 12** Level electrode NRG 10-52, NRG 16-52, five pole connector
- 13** Level electrode NRG 16-36
- 14** Level electrode ER 5..., 4 pole connector
- 15** Level electrode ER 5..., 6 pole connector
- 16** Level electrode NRG 16-4
- 17** Central earthing point (CEP) in control cabinet

In the plant: Wiring level electrode - continued -

Connection of level electrode

The level switch NRS 1-52 can be used in combination with the following level electrodes:

Level electrodes				
NRG 10-52, NRG 16-52 Electrode with 4 rods	NRG 16-36 Electrode with 4 rods	NRG 16-4 Electrode with 1 rod	ER 50 Electrode with 4 rods	ER 56 Electrode with 4 rods

To connect the level electrode(s) use screened multi-core control cable with a min. conductor size 0.5 mm², e. g. LiYCY 3 x 0.5 mm², max. length: 100 m.

Wire terminal strip in accordance with the examples **Fig. 4 to 8**.

Check the connection of the screen to the central earthing point (CEP) in the control cabinet.



Attention

- Please observe the instructions given in the installation & operating manual for the NRG 10-52, NRG 16-52, NRG 16-36, NRG 16-4 and ER 5.-1!
- Make sure that connecting cables leading to the level electrodes are segregated and run separately from power cables.

Factory settings

Level switch NRS 1-52

The level switch features the following factory set default values:

- Response sensitivity: 10 µS/cm (at 25 °C)

Commissioning procedure



Danger

The terminal strips of the equipment are live during operation.

This presents the danger of electric shock!

Always **cut off power supply** to the equipment before mounting, removing or connecting the terminal strips!

Changing response sensitivity

If the electrical conductivity of water is $< 10 \mu\text{S}/\text{cm}$ at 25°C change the response sensitivity to $0.5 \mu\text{S}/\text{cm}$ as follows:

- Cut off supply voltage.
- Remove **lower** terminal strip. **Fig. 9**
 - Insert a screwdriver to the right and left between the terminal strip and the front frame.
 - Unlock terminal strip on the left and right side. For this purpose move screwdriver in direction of the arrow .
 - Remove the terminal strip.
- Set switch S4 of code switch **18** to ON (= response sensitivity $0.5 \mu\text{S}/\text{cm}$).
- Re-attach lower terminal strip.
- Apply supply voltage. Equipment is restarted.

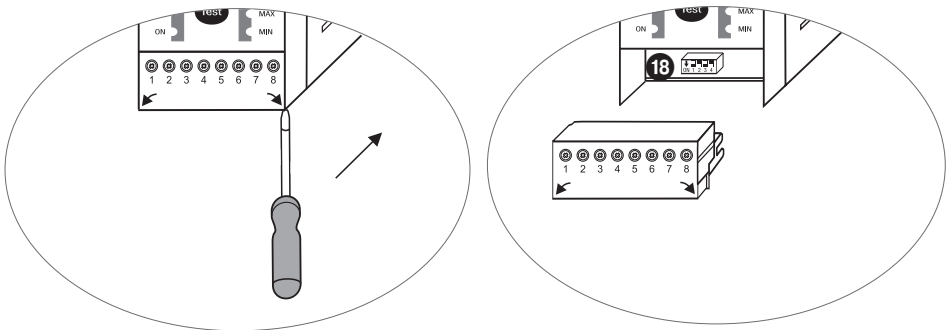

Fig. 9



Toggle switch, white

Fig. 10



Attention

Do **not** change the code switch **18** settings of S1, S2 and S3!

Checking switchpoint and function

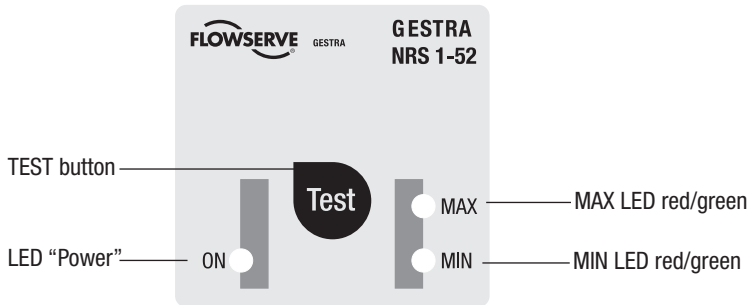

Fig. 11

Start		
Activity	Display	Function
Switch on supply voltage. Water level between MIN and MAX.	LED "Power" is illuminated	
	MIN LED illuminated green	MIN electrode rod immersed.
	MAX LED illuminated green	MAX electrode rod exposed.

Checking switchpoint and function		
Lower water level until it is below MIN level. MIN electrode rod is exposed.	MIN LED flashes red.	De-energizing delay is running.
	MIN LED illuminated red	Time delay elapsed, MIN output contact 16/18 closed, 17/18 open.
Fill vessel until MAX level is exceeded. MAX electrode rod enters the water.	MAX LED flashes red	De-energizing delay is running.
	MAX LED illuminated red	Time delay elapsed, MAX output contact 21/23 closed, 22/23 open.

Possible installation faults		
Status and indication	Error	Remedy
Water level below MIN switchpoint, MIN LED illuminated green.	MIN electrode rod is too long.	Cut electrode rod according to MIN switchpoint.
	If installed inside the boiler: Upper vent hole in protection tube does not exist or is obstructed.	Check installation of level electrode. Make sure that the level in the protection tube corresponds to the actual water level.
Water level between MIN and MAX. MIN LED illuminated red	MIN electrode rod is too short.	Replace level electrode and cut electrode rod(s) to the length dictated by MIN switchpoint.
	The earth connection to the vessel is interrupted.	Clean seating surfaces and screw in level electrode with metallic joint ring. Do not insulate the electrode with hemp or PTFE tape!
	Electrical conductivity of the boiler water too low.	Change response sensitivity to 0.5 $\mu\text{S}/\text{cm}$
	Upper vent hole flooded.	Check installation of level electrode. Make sure that the level in the protection tube corresponds to the actual water level.

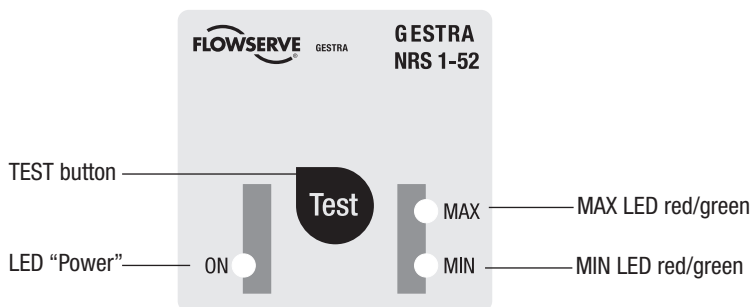

Fig. 11

Possible installation faults		
Status and indication	Error	Remedy
Water level above MAX switchpoint, MAX LED illuminated green.	MAX electrode rod is too short.	Replace level electrode and cut electrode rod(s) to the length dictated by MAX switchpoint.
	The earth connection to the vessel is interrupted.	Clean seating surfaces and screw in level electrode with metallic joint ring. Do not insulate the electrode with hemp or PTFE tape!
	Electrical conductivity of the boiler water is too low.	Change response sensitivity to 0.5 $\mu\text{S}/\text{cm}$
	If installed inside the boiler: Upper vent hole in protection tube does not exist or is obstructed.	Check installation of level electrode. Make sure that the level in the protection tube corresponds to the actual water level.
Water level between MIN and MAX. MAX LED illuminated red.	MAX electrode rod is too long.	Cut electrode rod according to MAX switchpoint.
	Upper vent hole flooded.	Check installation of level electrode. Make sure that the level in the protection tube corresponds to the actual water level.
Water level between MIN and MAX. MIN and MAX LEDs are flashing simultaneously.	MAX electrode rod is longer than MIN electrode rod.	Check and change the electrical connection of the level electrode.

Operation, Alarm and Test

Indicators and adjustors

Operation		
Status	Display	Function
Water level between MIN and MAX.	MIN and MAX LEDs illuminated green.	MIN output contact 16/18 open, 17/18 closed. MAX output contact 21/23 open, 22/23 closed.

MIN alarm		
Water level below MIN switchpoint.	MIN LED flashes red.	De-energizing delay is running.
	MIN LED illuminated red	Time delay elapsed, MIN output contact 16/18 closed, 17/18 open.

MAX alarm		
Water level above MAX switchpoint.	MAX LED flashes red.	De-energizing delay is running.
	MAX LED illuminated red	Time delay elapsed, MAX output contact 21/23 closed, 22/23 open.

Testing MIN alarm and MAX alarm		
During operation: Water level between MIN and MAX. Press and hold down button "Test".	MAX LED flashes red.	De-energizing delay is running.
	MAX LED is illuminated red for 3 sec.	MAX output contact 21/23 closed, 22/23 open.
	MIN and MAX LEDs illuminated green for 1 sec.	MAX output contact 21/23 open, 22/23 closed. MIN output contact 16/18 open, 17/18 closed.
	MIN LED flashes red.	De-energizing delay is running.
	MIN LED is illuminated red for 3 sec.	MIN output contact 16/18 closed, 17/18 open.
The test is finished. Release button "Test". Equipment returns to operating mode.	Note: If you continue to hold down the Test button, a new test is started. You can abort the test any moment by releasing the Test button.	

Further Notes

Action against high frequency interference

High-frequency interference can be caused by out-of-phase switching operations. Should sporadic failures or malfunctions occur take the following remedial actions in order to suppress interference:

- Provide inductive loads with RC combinations according to manufacturer's specification to ensure interference suppression.
- Increase the distance to sources of interference.
- Check the connection of the screen to the central earthing point (CEP) in the control cabinet.
- HF interference suppression by means of hinged-shell ferrite rings.
- Make sure that connecting cables leading to the level electrodes are segregated and run separately from power cables.

Decommissioning / replacing the equipment

- Switch off supply voltage and **cut off power supply** to the equipment.
- Remove the lower and upper terminal strips. **Fig. 9.**
- Release the white fixing slide at the bottom of the equipment and take the equipment off the supporting rail.

Disposal

For the disposal of the equipment observe the pertinent legal regulations concerning waste disposal.

If faults occur that are not listed above or cannot be corrected, please contact our service centre or authorized agency in your country.



GESTRA

Agencies all over the world:

www.gestra.de

Great Britain

Flowserve GB Limited

Abex Road
Newbury, Berkshire RG14 5EY
Tel. 0044 16 35 / 46 99 90
Fax 0044 16 35 / 3 60 34
E-Mail gestraukinfo@flowserve.com
Web www.flowserve.com

Singapore

Flowserve Pte. Ltd.

12 Tuas Avenue 20
Singapore 63882
Tel. 0065 / 68 79 89 00
Fax 0065 / 68 62 49 40
E-Mail fcd_gestra_singapore@flowserve.com
Web www.gestra.com

South Africa

Flowserve SA (Pty) Ltd.

Unit No. 1
Director Road
Spartan Extension 2
Kempton Park 1613
Tel. 0027 11 / 9 23 73 00
Fax 0027 11 / 9 74 64 20
E-Mail tvniekerk@flowserve.com
Web www.flowserve.com

USA

Flowserve GESTRA U.S.

2341 Ampere Drive
Louisville, KY 40299
Tel. 001 502 / 267-22 05
Fax 001 502 / 266-53 97
E-Mail fcd-gestra-usa@flowserve.com

GESTRA AG

P. O. Box 10 54 60, D-28054 Bremen
Münchener Str. 77, D-28215 Bremen
Tel. 0049 (0) 421 35 03 - 0
Fax 0049 (0) 421 35 03 - 393
E-Mail gestra.ag@flowserve.com
Web www.gestra.de

